



Modulus Flip

Assembly Instructions

Modulus Flip

Components List

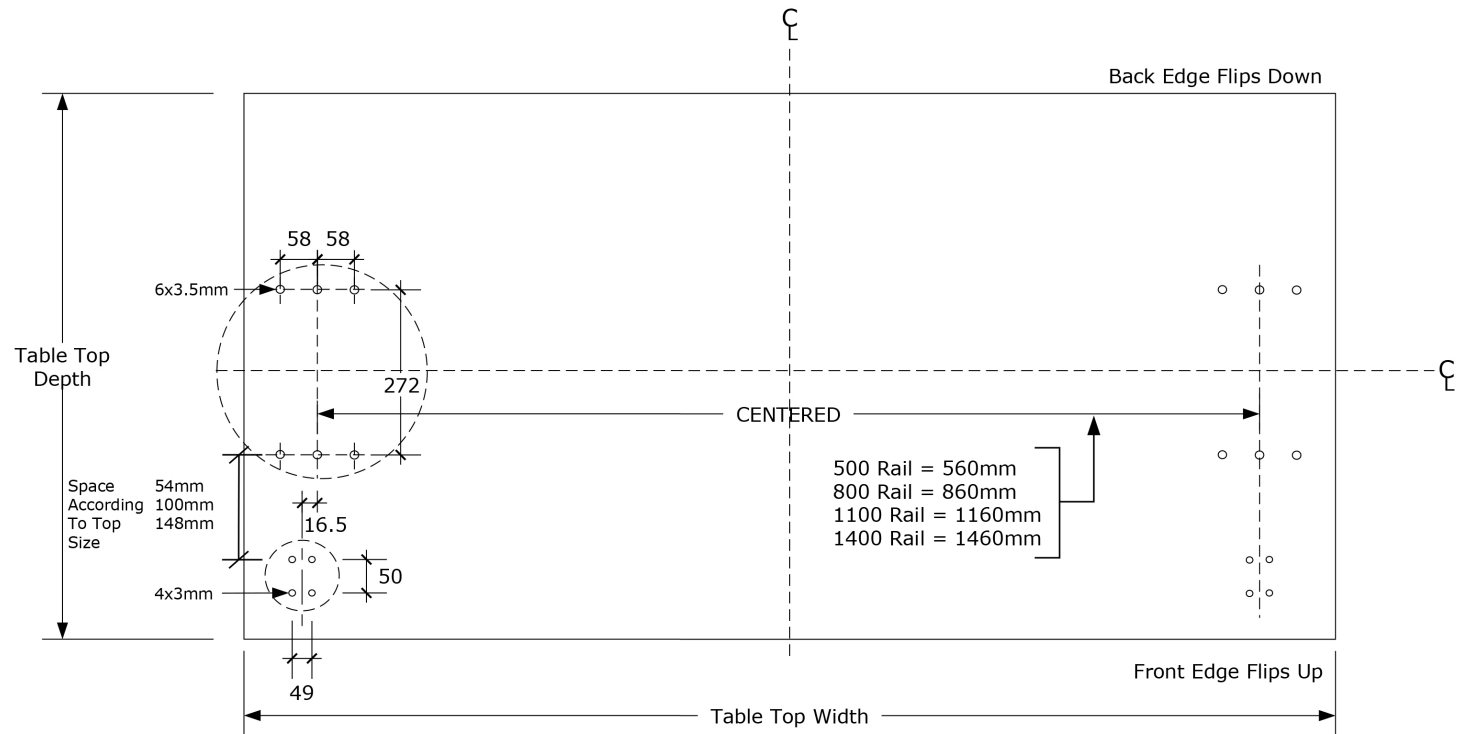

Statement of Use:

Modulus flip tables are designed for heavy commercial use & in boardrooms, conference rooms & training rooms.

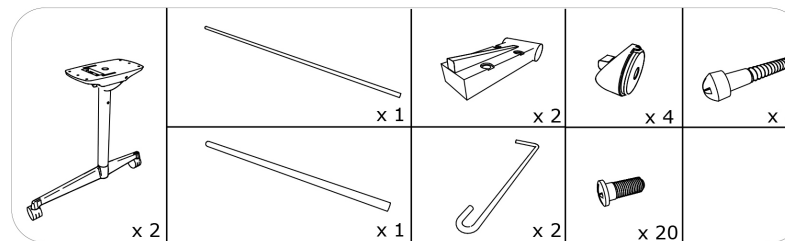

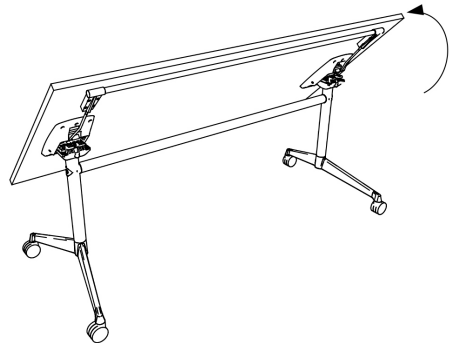
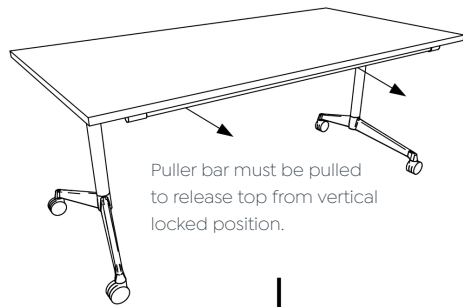

Step 1:

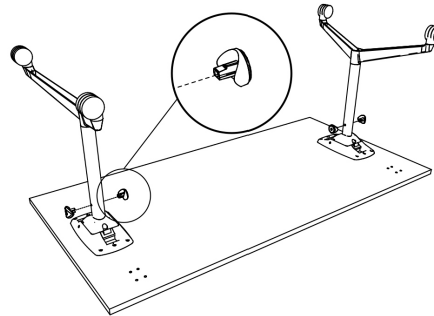

Step 2:

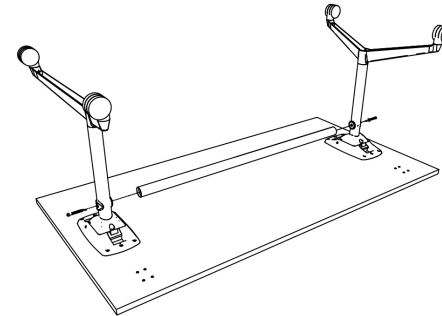

Step 3:

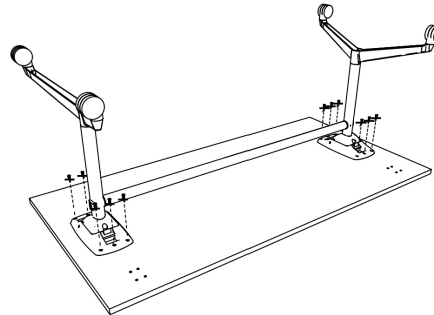

Step 4:

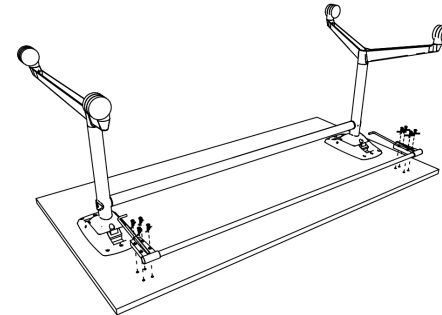

Modulus Flip

Assembly Instructions

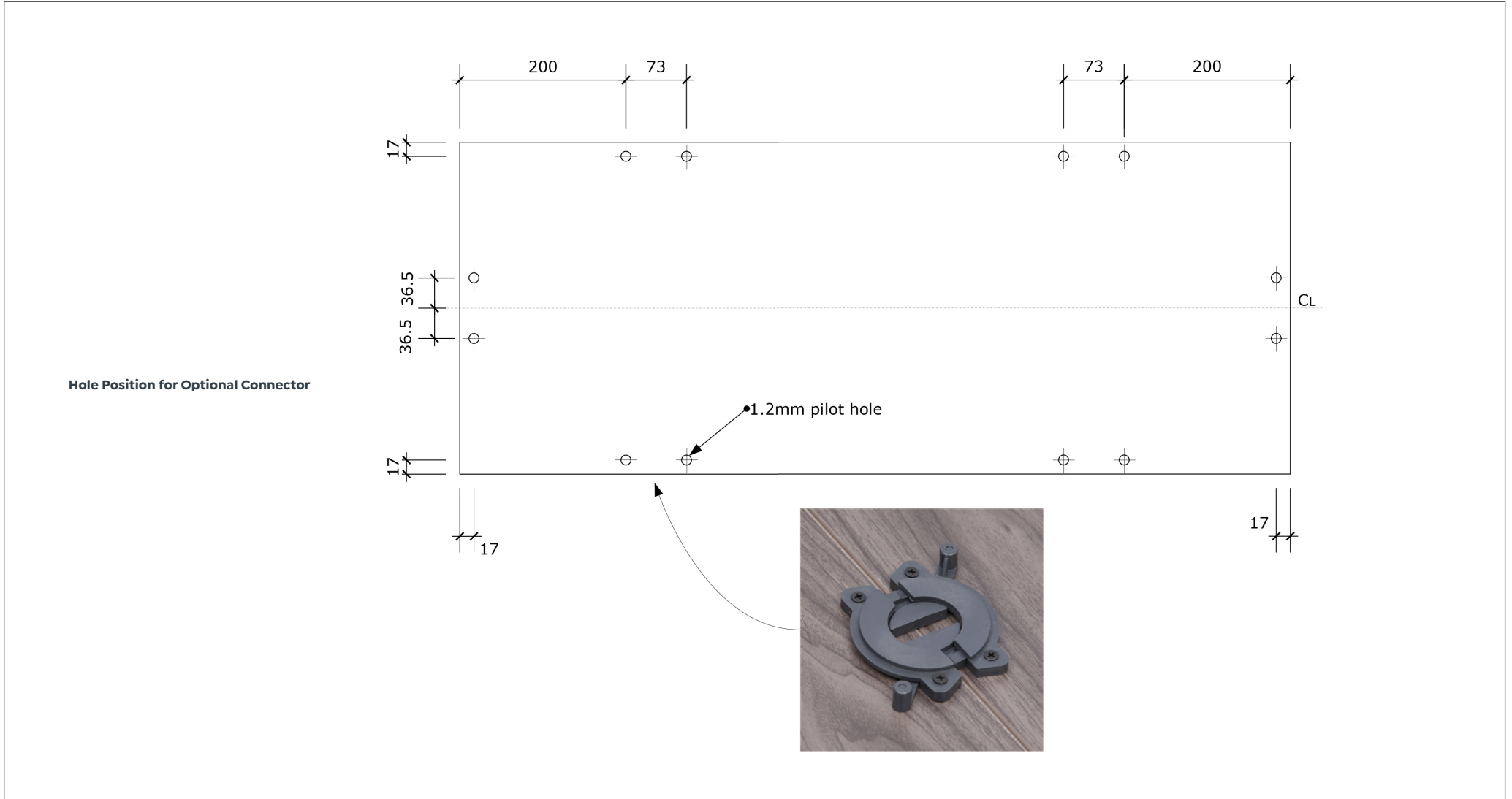

ANNUAL CHECK:

Once every 12 months make sure all the mounting bolts on the underside of the table top are tight, the castors run smoothly and the flip mechanism operates smoothly.

TOP CARE

Modulus tables are supplied standard with melamine tops. Clean tops regularly by wiping them down with a damp cloth and a general purpose cleaner/detergent. For best results use streak free glass cleaner.

Stain and Mark Removal

- Stubborn marks or stains – apply Handy Andy or diluted Janola (1 part to 3 parts water), then wipe down with a warm damp cloth.
- Smearing, finger marks, marking from cold or hot dishes, stickiness – apply 1 or 2 applications of acetone (available at pharmacies) and wipe over with dry cloth.
- Felt pen or dry marker – use methylated spirits or acetone
- Paint – use acetone or thinners (from a paint shop)
- Glue – contact type – use Ados Solvent N (from a paint shop)

Follow on with streak free glass cleaner to remove any residues.

FRAME CARE

Keep the plastic & metal components of your table clean by wiping them down with a damp cloth and a general purpose cleaner/detergent. For best results use streak free glass cleaner.